

Item	PartNum	Qty	Description	Material	Pkg
1	1036-057	1	36 x .313" NOM SHELL	SA-516 GR 70	
2	20-234	2	36" x .375 NOM 2:1 ELLIP. HEAD	SA-516 GR 70	
3	40-1163	2	1/2" THICK LIFT LUG	SA-516 GR 70	
4	40-2626	2	36" SADDLE BRACKET	SA-36	
5	30-031	2	1-1/2" NPT HALF COUPLE 3000#	SA-105	
6	30-021	2	1/2" NPT COUPLING 3000#	SA-105	
7	30-005	1	1/4" NPT COUPLING 3000#	SA-105	
8	160-003LS	1	LIBERTY NAMEPLATE	Stainless Steel	
9	150-043	2	PROTECTOR	Vinyl	X
10	150-064	1	PROTECTOR	Vinyl	X
11	150-062	2	PROTECTOR	Vinyl	X

TACK WELD BRACKETS TO SHELL
IN ORDER A-B-C, THEN FINISH WELD.

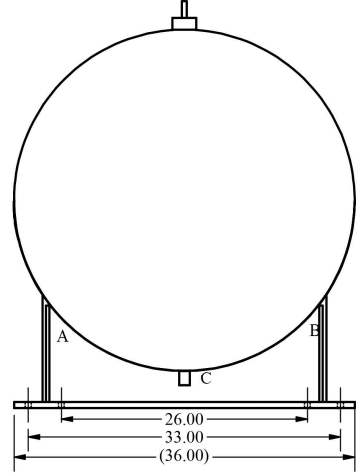

- NOTES:
1. ALL JOINT WELDED.
 2. 225 PSIG MAX. WORKING PRESSURE.
 3. FINISH: RAL-9005 BLACK POWDER PAINT.
 4. HYDROSTATIC TEST PRESSURE - 293 PSIG.
 5. MANUFACTURE VESSEL IN ACCORDANCE W/ ASME SEC. VIII, DIV. 1 (LATEST EDITION) RULES FOR CONSTRUCTION.
 6. MIN. DESIGN METAL TEMP. = -20°F.
 7. MAX. DESIGN TEMP. = 500°F.
 8. "U" STAMPING REQUIRED.
 9. USE WPS MIG-1-PA OR WPS SUB-ARC-1-PA FOR ALL WELDING.
 10. CORROSION ALLOWANCE: 0".

ENGRAVE CUSTOMER PART NUMBER IN PART/ TAG NO. BOX

Tolerances unless otherwise specified			
0.000 = ± .060		Angular = ± 2°	
0.00 = ± .250		☞ unless otherwise specified	
Description 36" x 96" HORZ. RECEIVER			
Customer/Material LIBERTY 43108			
Weight 1207#	Capacity 380 GAL		
Date 2/2/2021	By CM	Part No. RH3696F	Approved